

printing



INDUSTRY APPLICATION GUIDE

Printing Industry

Static Solutions to
Improve Production
and Profitability

Meech International

More than 6000 customers worldwide have benefited from the expertise and product-based solutions provided by Meech International. With an unparalleled knowledge of the effects of static in manufacturing processes, the company has developed an impressive portfolio of static control and cleaning systems. These are designed to enable customers to improve their own production processes and hence profitability.

Throughout the world, businesses benefit from Meech expertise. A truly international company, Meech has its headquarters in the UK and additional operations in the USA, Belgium, Hungary and China, supported by a worldwide distribution network covering over 50 countries.

Meech has built its present success on offering its customers outstanding levels of:

- Applications Knowledge
- Flexibility of Approach
- Innovation
- Speed of Response

...and these are the qualities that will continue to underpin future growth.

Meech Technology

For further information, please refer to the Meech web site (www.meech.com) or the "Static Electricity: Causes and Cures" booklet.

Static Elimination

Meech provides solutions based on both AC and Pulsed DC technologies for optimum static control. AC technology takes normal mains voltage and boosts it (typically to 7kV) through a special transformer. This high voltage is carried to an array of emitter pins to create a high energy "corona". A very large number of positive and negative ions are generated following the AC cycle. A statically charged surface of either polarity passing close to this ion cloud will be quickly neutralised.

Meech special Pulsed DC technology transforms mains voltage into positive and negative outputs. Dedicated emitters produce alternating clouds of positive and negative ions. Frequency and ion balance (the relative proportion of positive and negative ions) can be adjusted to optimise long distance neutralisation for specific materials and process conditions.

Static Generation

Generating a controlled static charge on a non-conductive material will allow temporary adhesion between two or more surfaces of opposite polarity. A high DC voltage of up to 50kV (positive or negative, depending on the application) is carried to a special array of emitter pins to create a "corona". With the emitter pins positioned in close proximity to a grounded surface, material passing into the field will be charged and bonded to adjacent surfaces.

Cleaning

Dust contamination presents major problems in a wide range of manufacturing industries. The removal of dust can be substantially improved by the use of static control systems. Meech "JetStream" technology combines a specialist knowledge of static control and air flow to provide a unique design of manifold with an integrated ionisation system. Driven by energy efficient fans, the JetStream produces a high velocity blade of ionised air capable of removing contaminants down to 1 micron.

Static Control Problems in the Printing Industry

Problems with static electricity in the printing industries are numerous. Processes that can be adversely affected by static include litho and web printing, screenprinting, inkjet printing as well as digital and laser printing.

The primary problems resulting from high levels of static charge are:

- Process Control & Quality Problems
- Dust Attraction & Contamination
- Operator Shocks
- Ink Spidering/Webbing
- Possible Fires & Explosions

Double Sheet Feeding

When feeding a stack of sheets into an offset press, folder, die cutter or other machines, a common problem is that the sheets will double feed into the press. This results in paper jams, misregistration and press downtime.

The only way to properly manage this problem is to remove the static charge from in between the sheets as they are being fed into the machine. Simply trying to remove the charge from the top surface of the sheet alone is not normally sufficient.

Poor Sheet Stacking and Delivery

Static charge built up on the sheets during the printing process will often result in the sheet not stacking properly. The static charge will cause the sheets to be attracted to one another prematurely and not allow them to "float" on to the stack.

This results in an uneven stack that is cosmetically unappealing and can also result in problems if the stack is to be fed into an additional finishing process.

Dust Attraction and Contamination

The attraction of airborne contaminants as a result of static charge on a substrate is becoming more and more of an issue as print quality standards continue to be raised.

The dust and particulates attracted by the high static charge on the web or sheet can result in high and expensive scrap rates.

Ink Spidering/Webbing

Static charge build-up on substrates can have severe detrimental effects on the ink.

On digital and inkjet printers, the static charge on the substrate can cause the ink to be deflected from its intended path. This can lead to poor print quality and blockage of the printing head.

A similar problem can occur in screenprinting when the squeegee comes in contact with the mesh screen.

Fires & Explosions

The use of flammable gases and solvents is commonplace in many printing and converting processes.

Significant build up of static charge on the web could result in a static discharge and the associated risk of ignition of the flammable gases in the area. This at a minimum can result in a small localised fire but has also been known to cause much more extensive damage.

Applications

Offset Litho Press Infeed

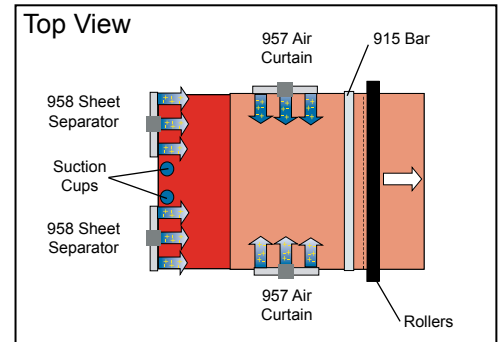
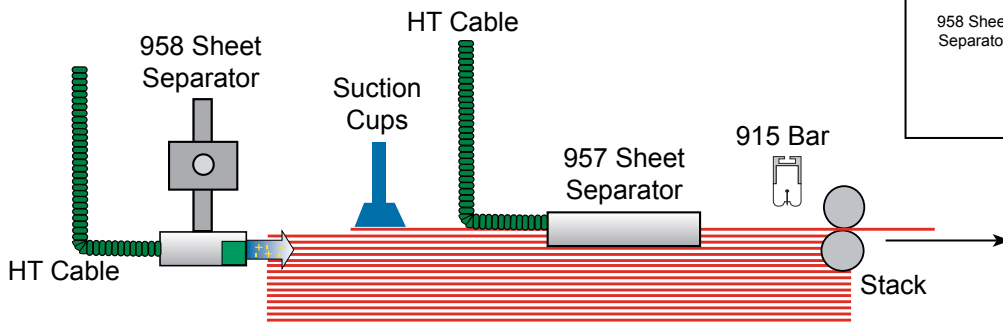

Problem:

High speed offset printing machines can produce very high static charges on coated paper stock:

1. Sheets will not feed at speed.
2. Sheets stick together.
3. Mis-registration.
4. Sheet Jamming.

Solution:

Careful placement of ionising air curtains or nozzles at the sheet sides will maintain a constant stream of ionised air between the top sheet and the stack, preventing sheet adhesion. The continuous blast of ionised air helps float the sheet and removes the static charge.

Alternatively: For less severe problems, ionising air nozzles can also be used.

Litho Press Sheet Delivery

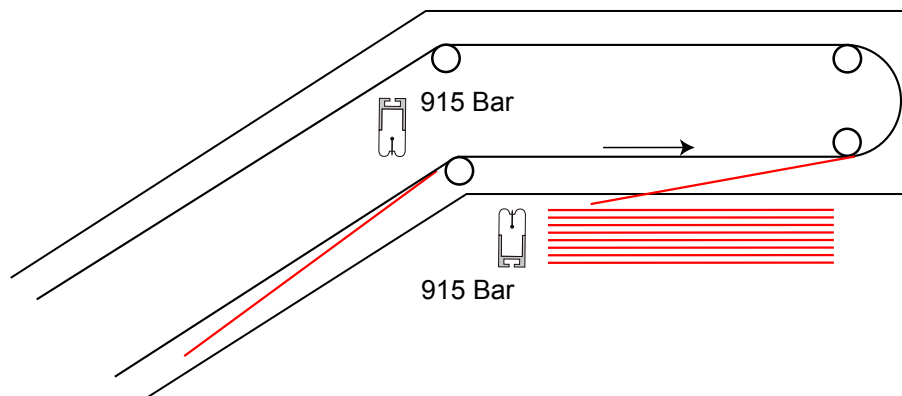

Problem:

A very high static charge can accumulate on sheets due to the printing and conveying process throughout the machine, resulting in:

1. Uneven delivery stack.
2. Disruption of further finishing processes down the line.

Solution:

The use of powerful ionisers is critical in this area in order to avoid the moving grippers and the Model 915 Bar is ideal. It is best to neutralise both sides of the sheet as close to the delivery pile as possible.

Applications

Shingled Sheet Delivery

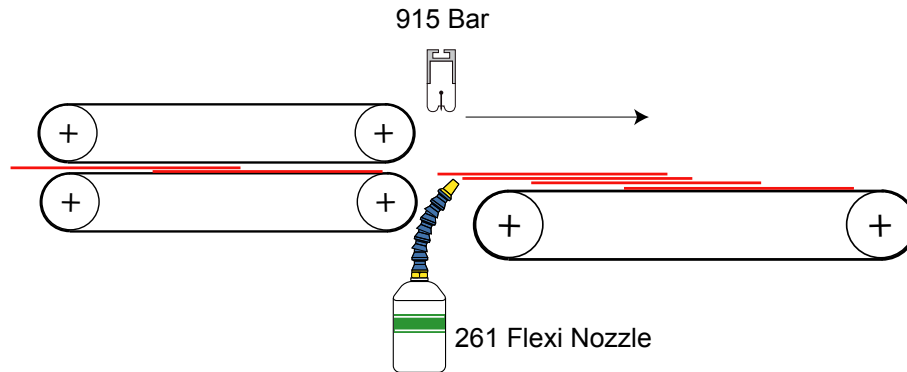

Problem:
When delivering single or shingled (overlapped) sheets on to either a conveyor or a stack, static causes the sheets to cling together resulting in collation problems.

The problem is more pronounced on shingle type delivery systems. It is important that the static charges are eliminated from between the individual sheets.

Solution:
Single or multiple 261 DC Ionisers fitted with flexible air output nozzles can be positioned in such a way that the ionised air flows between the sheets during the delivery process.

Model 915 Bars positioned as shown ensure full and effective neutralisation of static charges across the full sheet width.

Flexo Winders

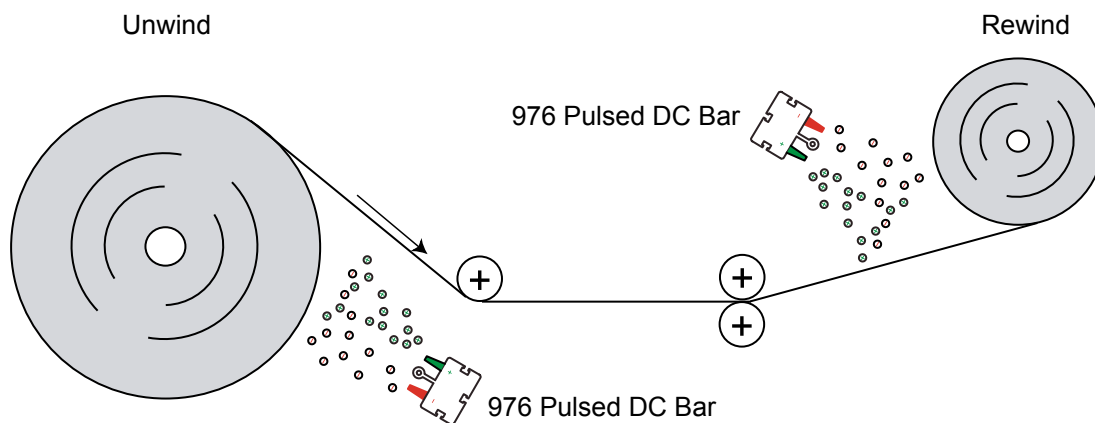

Problem:
A very high static charge can accumulate on rolls due to the "battery effect". This can cause various problems such as:

1. Unpleasant operator shocks.
2. Dust attraction, leading to contaminated stock.
3. Poor quality wound reels that can be difficult to fit on to machines and may cause feed problems.

Solution:
The most effective solution is to use Meech Pulsed DC technology with Model 976 Bars positioned as shown above. The positioning of a Model 976 Bar at the unwind reel is optional but, if fitted, will provide full control of static charges.

Applications

Screen Printing

Flatbed

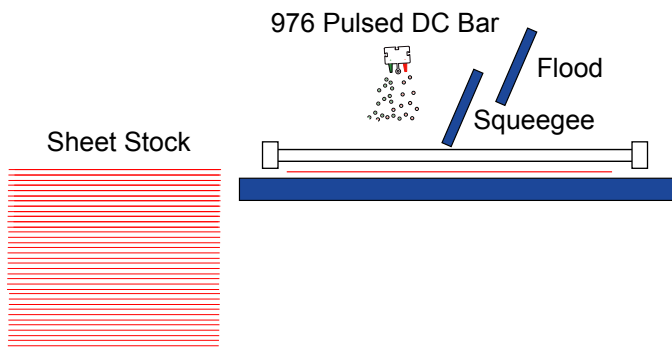

Cylinder

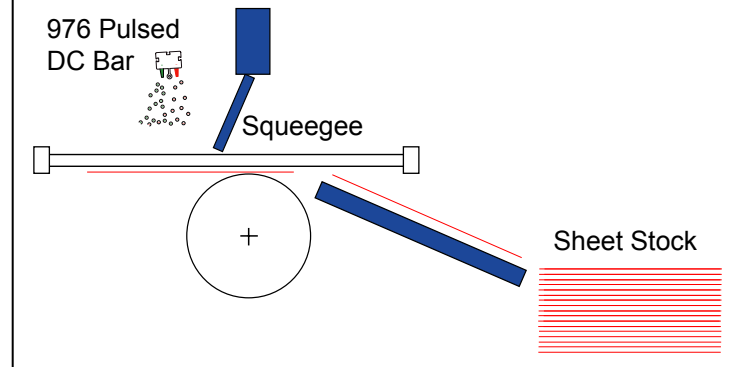

Problem:

On flatbed and cylinder screen printing machines, static charges generated during the printing process can cause several problems:

1. Substrate sticking to the screen after it is printed.
2. Ink spidering and webbing.
3. Dust attraction to the screen and substrates.

Solution:

Placing a long range Model 976 Pulsed DC Bar over the width of the screen will effectively neutralise the charge on the screen and substrate as soon as it is generated by the squeegee.

Tampo/Pad Printing

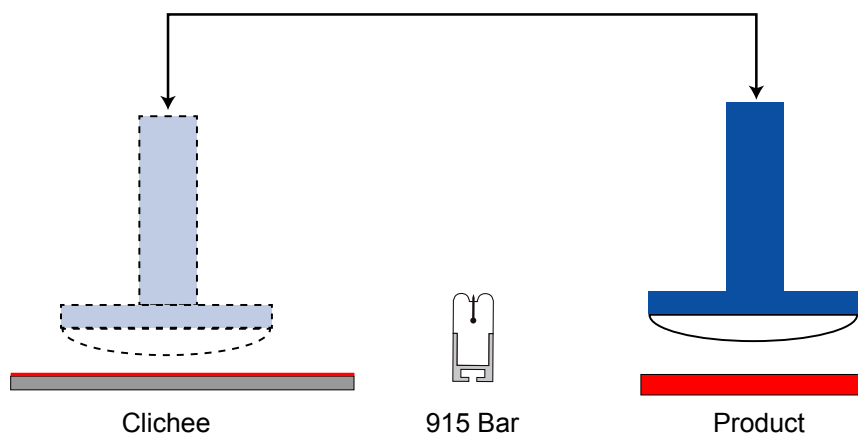

Problem:

Typical static-related problems are ink spidering or webbing. The cause can be static charge in the pad or in the product, or the charge generated when the pad hits the product.

Solution:

The solution depends on the specific design of the machine. If the charge is in the pad it can be neutralised with a 915 Bar positioned as above. Alternate positions may also be used.

Applications

Folding

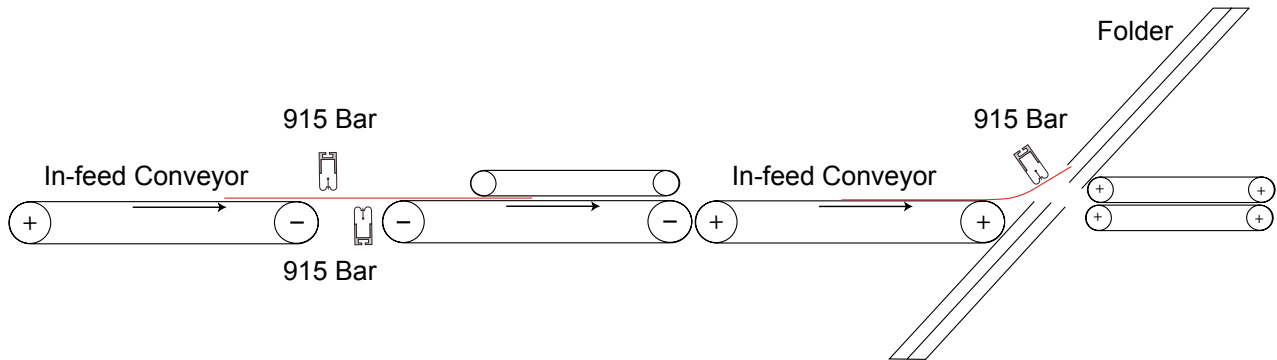

Problem:

On high speed multi page folding stations, static charges on the sheets can lead to major problems such as:

1. Sheet fouling in folding gates.
2. Inability of sheets to feed through the delivery system.
3. Expensive and disruptive down time to clear the folding stations.
4. Substantially reduced operating speeds.

Solution:

Model 915 Ionising Bars placed at the base of the gates of both double folding stations provides powerful, concentrated ionisation to neutralise the static charges.

Flexo Gravure

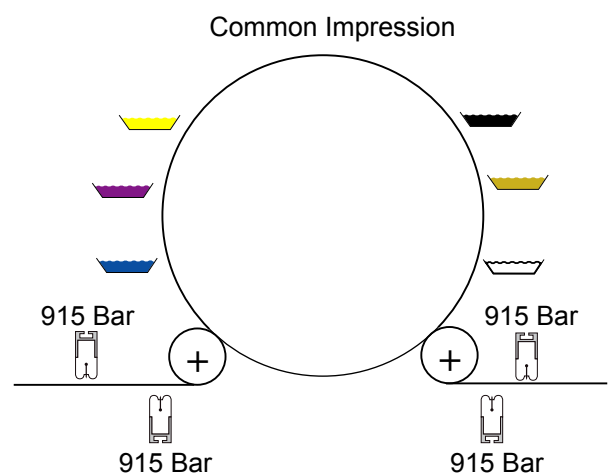
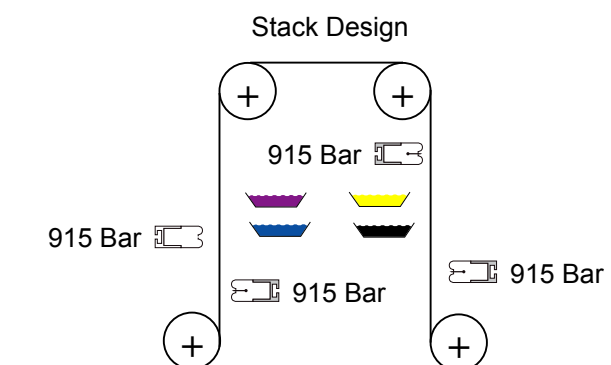

Problem:

There are 2 common designs of web machine - stack format and common impression cylinder. In both cases, the objective is to ensure that the substrate is free of charge at each print station. Uncontrolled static will cause the ink to misbehave as well as present the risk of a spark discharge igniting flammable solvent.

Solution:

The strategic positioning of standard or Ex-rated 915 Bars will resolve most static problems.

Applications

Wide Format Digital Printing

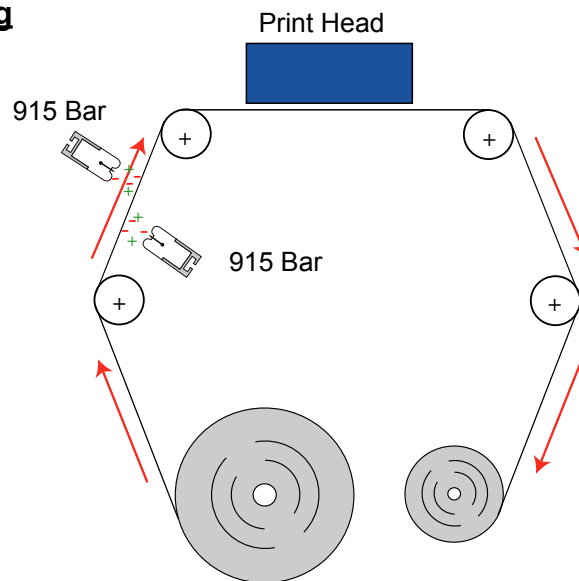

Problem:

A very high static charge can be generated on the substrate as it is unwound from the roll. This can cause:

1. Repelling of the ink which causes ink spidering or webbing.
2. Damage to sensitive electronic components in the printer.
3. Operator shocks.

Solution:

The most common solution is the placement of Model 915 Ionising Bars on each side of the web just prior to it entering the print head.

The long range capability of the bars will alleviate any concerns due to changes of the web path.

Inkjet Printing

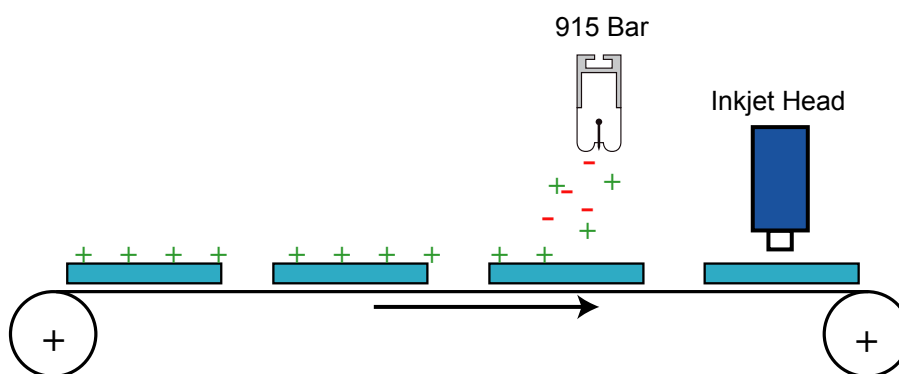

Problem:

High static charges generated on plastic extrusions, containers, boxes etc can present a number of problems for ink jet printing systems:

1. Attraction of dust to the surface being printed.
2. Deflection of the ink jet, resulting in poor print quality.
3. Electronic failure of ink jet printing equipment.
4. Contamination of the directional deflector plate leading to lost production time due to cleaning.

Solution:

The positioning of a long range Model 915 Ionising Bar prior to the print head will neutralise the static charge and ensure:

1. No dust attraction.
2. Improvement of print quality.
3. No electrostatically generated electronic failure.
4. A clean direction deflector plate resulting in reduced cleaning and improved productivity.

Applications

Compensating Stacker

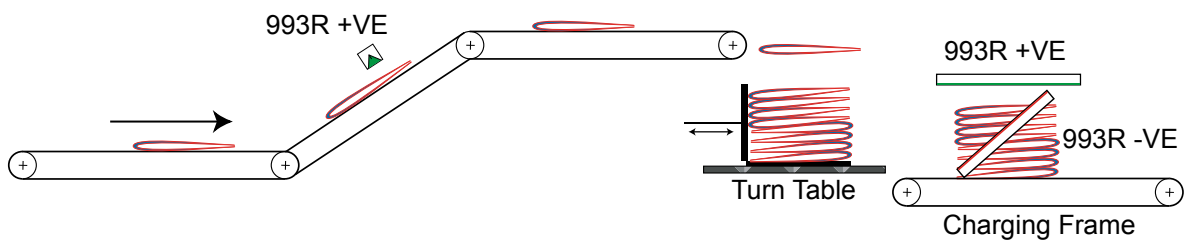

Problem:
Compensating stackers suffer from unstable stacks which often collapse on delivery conveyors. The “stay stacked” solution is ideal for ensuring stabilisation of stacked publications.

Solution:
The principle of the book collation pinning system is to pass the pre-stacked books through a static charging frame. The charge will lock the loose books together and create a more stable stack.

Web Cleaning

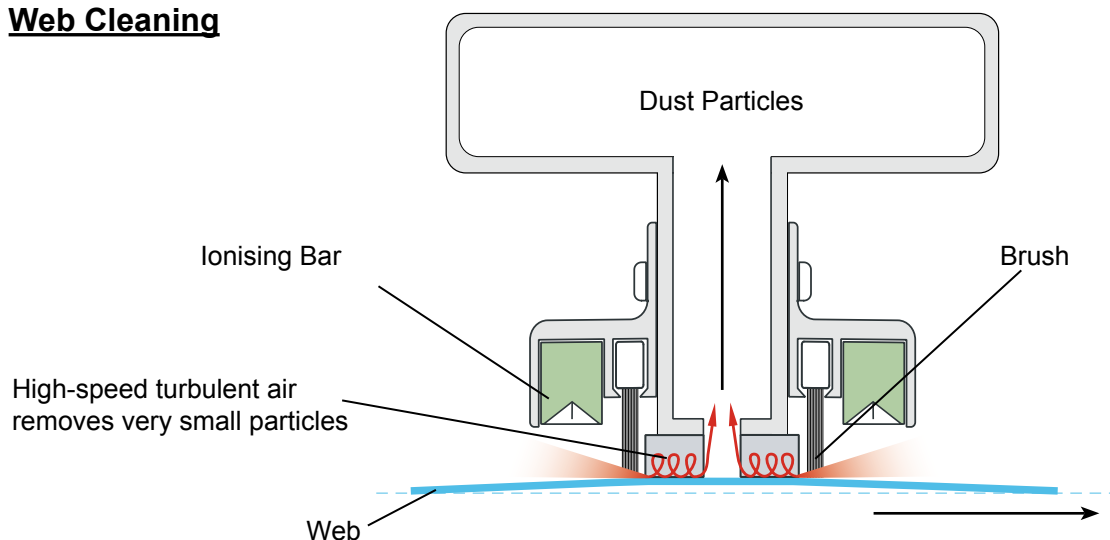

Problem:
Dirty webs can cause loss of profit and customer dissatisfaction, excessive down time on printing presses, high reject rates in laminating processes and unacceptable quality in pharmaceutical or food packaging.

Solution:
Using a combined process of static elimination, brushing and vacuum can provide effective removal of particulates from the web.

Product Summary



Model 983v2

The Model 983v2 has been designed to provide accurate measurement of static electrical charges.



Model 904

The Model 904 is a constant voltage power supply, designed to provide a 7kV source for Meech AC ionising equipment.



Model 915

The powerful performance of the Model 915 provides very fast decay times and effective ionisation up to distances of 152mm with a shockless design.



Model 915Ex

Model 915 designed for use in Hazardous Locations. Baseefa/ATEX and UL versions available.



Model 957

The Model 957 is an extremely versatile unit that provides effective static neutralisation, dust removal, and sheet separation capabilities.



Model 958

The Model 958 sheet separator allows efficient operation of automatic sheet feeders

Product Summary



Model 976

The Model 976 Pulsed DC Bar is unique and has been designed to provide highly effective long range ionisation up to distances of 610mm. It is shockless and is easily maintained.



Model 977v3 and 977CM

The Model 977v3 and 977CM Pulsed DC Controllers have been designed to operate with the full industrial range of Meech PDC equipment.



Model 261F

The Model 261Flexi Nozzle is a small, lightweight ioniser with the discharge outlet extended by flexible knuckle trunking.



Model Tornado F4 and F5

The Series Tornado Web Cleaning System has been designed to provide effective cleaning of the contaminants produced on all types of materials.



Model 993R

The Model 993R is a high performance sparkless Generator Bar used with the Meech range of high voltage DC static generators.



Model 992v3

The Model 992v2 Static Generator creates a controlled level of static charge to impart temporary bonding between materials.



Meech International

2 Network Point
Range Road, Witney
OX29 0YN, UK

Tel: +44 (0)1993 706700
Fax: +44 (0)1993 776977

email: sales@meech.com

Meech Static Eliminators USA Inc.

2915 Newpark Drive
Norton, OH 44203
USA

Tel: +1 330 564 2000 / 1 800 232 4210
Fax: +1 330 564 2005

email: info@meech.com

Meech Elektrostatik SA

Av C Grandprez 27
B 4970, Stavelot
Belgium

Tel: +32 8086 2983
Fax: +32 8086 2821

email: mesa@meech.com

Meech CE

2151 Fót
Széchenyi út. 46
Hungary

Tel: +36 27535075
Fax: +36 27535076

email: ce@meech.com

Meech China

Room 205, Huana Hotel Office Tower
No. 1733 Lianhua Road
Shanghai 201103
China PR

Tel: + 86 21 6119 6723/ 6119 6724
Fax: + 86 21 6119 6725
Mobile: 01380169 2517

email: china@meech.com