



Energy Saving Safety Nozzle

Energy Saving Safety Nozzles from Meech Air Technology can save up to 70% of compressed air demand whilst dramatically reducing noise levels.

APPLICATIONS:

- *Air saving: reduction of energy bills*
- *Compressor demand reduction*
- *Noise reduction*
- *Parts ejection*
- *Swarf removal*
- *Cooling of parts*

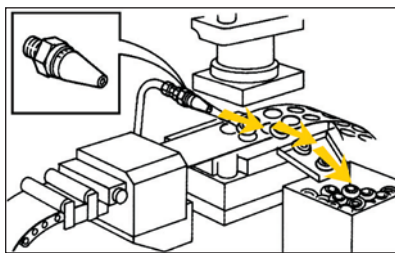

Parts Ejection

It requires high thrust to eject parts quickly from this stamping press. The adjustable output of the Model A48009 Nozzle can be set to do the job efficiently and quietly whilst also conserving compressed air.

DIMENSIONS:

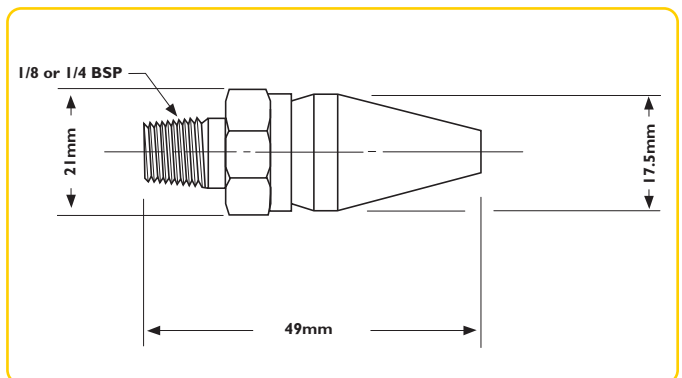

How it works:

The innovative nozzle design forces compressed air through an adjustable circular slot and then directs it at high velocity on to the outside of the nozzle cone (no air exits the hole at the end of the nozzle; a simple lock screw is located here for slot adjustment). This design amplifies the output airflow by entraining ambient air at a 25:1 ratio and is compliant with health and safety requirements.

FEATURES AND BENEFITS:

- | | | |
|-------------------|---|-----------------------------|
| Innovative design | - | 25:1 air amplification |
| | - | Up to 50dBA noise reduction |
| | - | Health and Safety compliant |
| No moving parts | - | Low maintenance |
| Adjustability | - | Application specific set-up |

PRODUCT NUMBERS AND DESCRIPTIONS:

A48009-1/8	-	Aluminium Energy Saving Nozzles, 1/8" bsp, 5 pack
A48009-1/4	-	Aluminium Energy Saving Nozzles, 1/4" bsp, 5 pack
A40009-1/8	-	Stainless Steel Energy Saving Nozzles, 1/8" bsp, 5 pack
A40009-1/4	-	Stainless Steel Energy Saving Nozzles, 1/4" bsp, 5 pack

Energy Saving Safety Nozzle



MEECH NOZZLE:

Inlet Air Pressure		Air Consumption		Sound Level	Thrust Level
psi	bar	cfm	lpm	dBa	Grams
20	1.4	8	227	66	60
40	2.7	11	312	72	130
60	4.1	13	368	76	202
80	5.4	15	425	78	285
100	6.8	17	473	80	335

OPEN PIPES:

Inlet Air Pressure		Air Consumption			
		1/8"		1/4"	
psi	bar	cfm	lpm	cfm	lpm
20	1.4	12	340	47	1331
40	2.7	16	453	66	1869
60	4.1	20	566	81	2294
80	5.4	23	651	93	2634
100	6.8	26	736	104	2945

PERFORMANCE GRAPH:

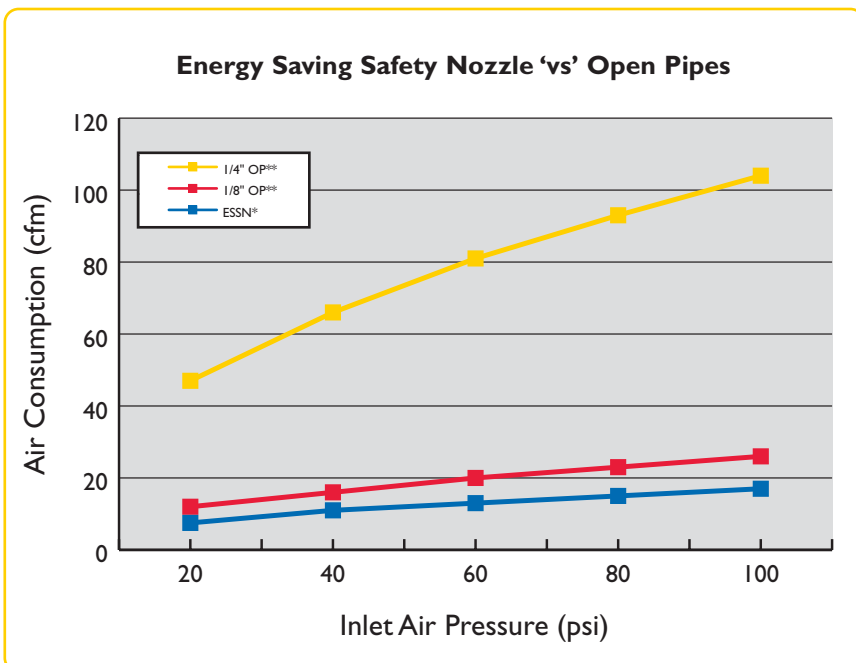

Energy Saving Example

Company 'A' uses 5 x 1/4" open air pipes running at 80psi inlet air pressure to keep a motor cool by blowing air over it. The open air pipes run constantly for 16 hours per day, 5 days per week, 48 weeks per year. Company 'A' has an electricity cost of 5p/kWhr.

Each 1/4" open air pipe has an air consumption of 93cfm, giving a total consumption of 465cfm (5x93).

By installing Meech Nozzles, dramatic air and cost savings can be made. When running at 80psi inlet air pressure each Meech Nozzle has an air consumption of 15cfm, giving a total consumption of 75cfm (5x15), less than 1 x 1/4" open pipe!

RUNNING COST COMPARISON:

Duration	1xESSN*	1xOP**	5xESSN	5xOP
Per Day	£2.25	£13.95	£11.25	£69.75
Per Week	£11.25	£69.75	£56.25	£348.75
Per Year	£540	£3,348	£2,700	£16,740

* ESSN - Energy Saving Safety Nozzle
** OP - Open Pipe

This shows that a massive 84% saving in annual running costs (equivalent to £16,740 - £2,700 = £14,040) can be achieved by installing 5 Meech Nozzles.

